



Racial Equity Committee

Thursday, March 14th

Public Comment

Committee Members & Public

10 Minutes



Welcome and Introductions

**Welcome our monthly Racial Equity
Committee meeting! Please share your
info in the chat:**

- Name
- Pronouns
- Race and/or Ethnicity
- Affiliation / Organization
- Any CoC Committee you serve on



Review the [CoC LB shared agreements](#)

- Community Builder
- [Action] Voting Members: Round 1 - Liaisons
- Liaison Development
- System Updates & Announcements

Nominations Committee - (ACTION) Member to Serve

NOFO Committee – (ACTION) REC Member to Serve

- April REC Committee meeting and workgroups
- April Community Meeting – Racial Equity Opportunity
- Adjourn

Next Meeting Thursday, April 11, 2024

Agenda



Community Builder

Nic Ming
10 minutes



Digital Altar

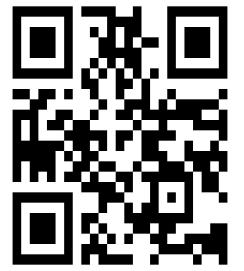

Digital Altar: Alameda CoC Racial Equity Committee

Add digital poem, song, picture or a piece of art that reflects you



Quilt Chase by Annie Bendolph

Human race we are;
Many Places we are from;
We seek to unite.
(Haiku style)

R¹



www.bing.com

India Arie song - Bing
Intelligent search from Bing makes it easier to quickly find what you're looking for and rewards you.



TENETS OF THE NAP MINISTRY

1. Rest is a form of resistance because it disrupts and pushes back against capitalism and white supremacy.
2. Our bodies are a site of liberation.
3. Naps provide a portal to imagine, invent, and heal.
4. Our DreamSpace has been stolen and we want it back. We will reclaim it via rest.

The caterpillar is a prisoner to the stream that consumed it
It is only able to eat or consume everything adjacent, in order to protect itself from the mad city
While consuming its environment, the caterpillar begins to realize songs to survive
One thought occurred to him: return to the world which fed him, but break the butterfly
The butterfly has eaten the caterpillar, the thought occurred, did the caterpillar swim the water table
But having a high school or a college degree does not mean you are smart, it only means you are
Already surrounded by the mad city, the caterpillar is trapped on the ground which made it possible for
He can no longer see what his own struggle is
He's trapped!
When trapped inside these walls, certain doors like ropes, buttons, going home, and bringing back how concepts to the mad city
The result?
Wings begin to emerge, breaking the cycle of being trapped
Finally free, the butterfly sheds light on situations that the caterpillar never considered, ending the stream's struggle
Although the butterfly and caterpillar are conceptually different, they are one and the same!



Activity: Shared Values

Reflect on the Item that you contributed to the digital Altar. Does it signify any universal values that are important to you?

Reflect on questions below and [share online](#):

- What are three values that are important to you as a person?
- What are three values that are important to your work?

Universal values: principles that are important

Activity: Shared Values -

Reflect and [share answers online](#)

3 Universal values that are important to you



Level Setting

5 minutes



REC Activities

REC activities main buckets

- Seat, Onboard, Train REC members
- Develop REC Committee Operational Structure
- Develop CoC RE Implementation Structure & Action Roll-Out
- Ongoing and Emerging CoC Areas

[Action] Voting Members

Homebase
20 minutes





How is REC Different?

- More members than other committees
 - Most other committees have 9-15 members
- Not all REC members are voting members
 - Other committees all members are also all the voting members
- Being a voting member on REC doesn't mean you stop being a voting member on another committee
- REC membership based on Standing Committees and Community / At-Large Members

Voting Seats on the REC

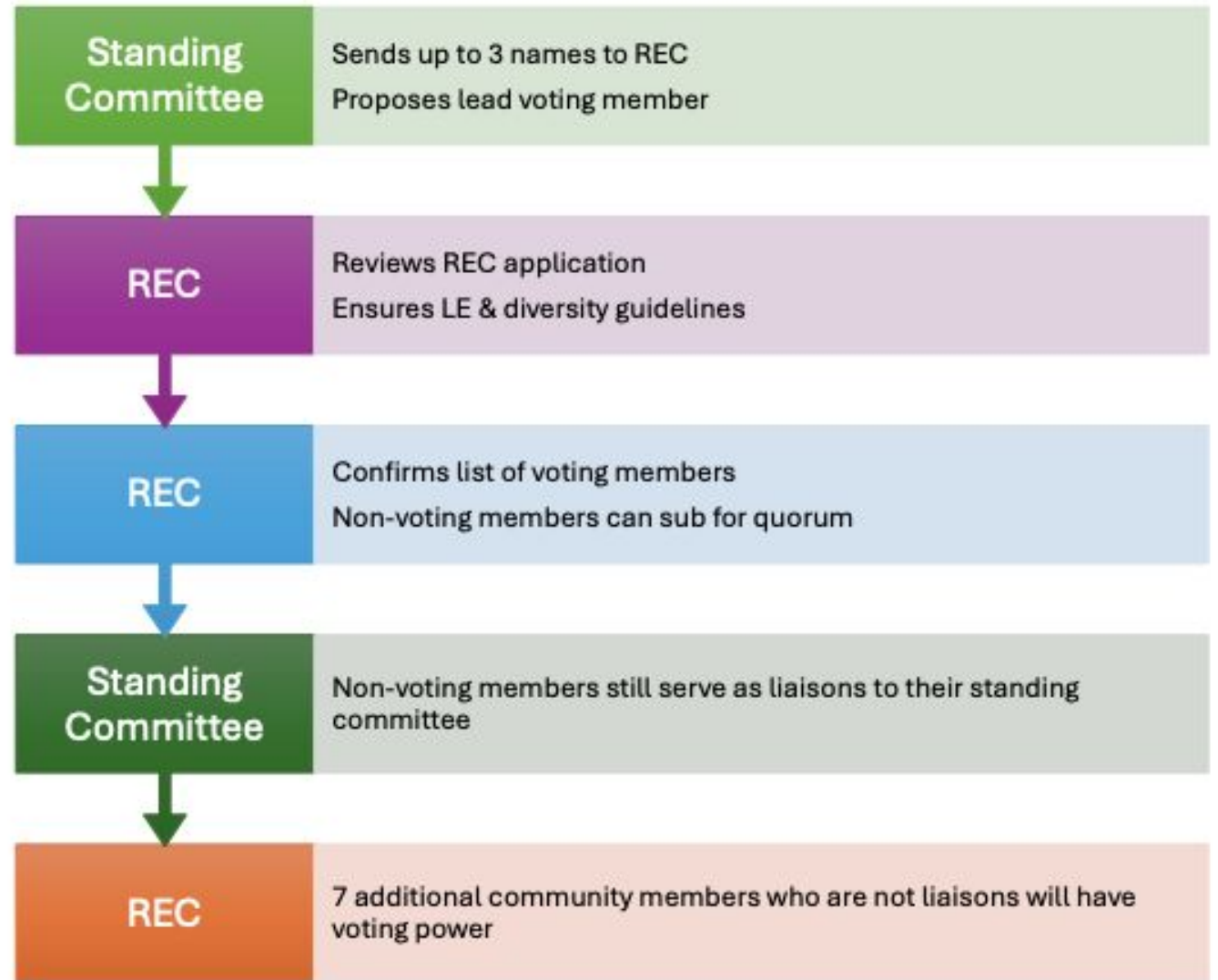

REC Seating up to 15 voting seats

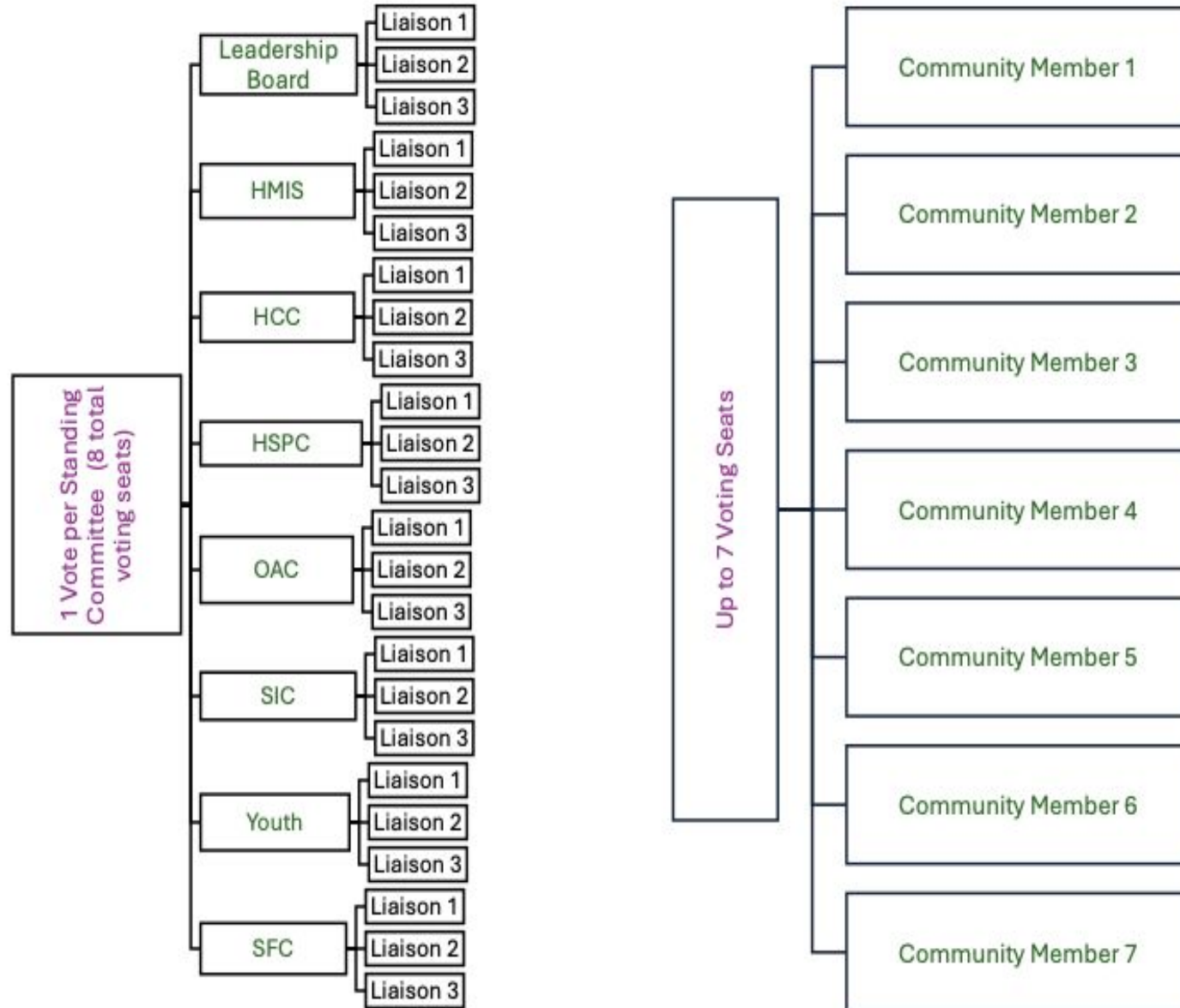

REC Seating up to 15 voting seats

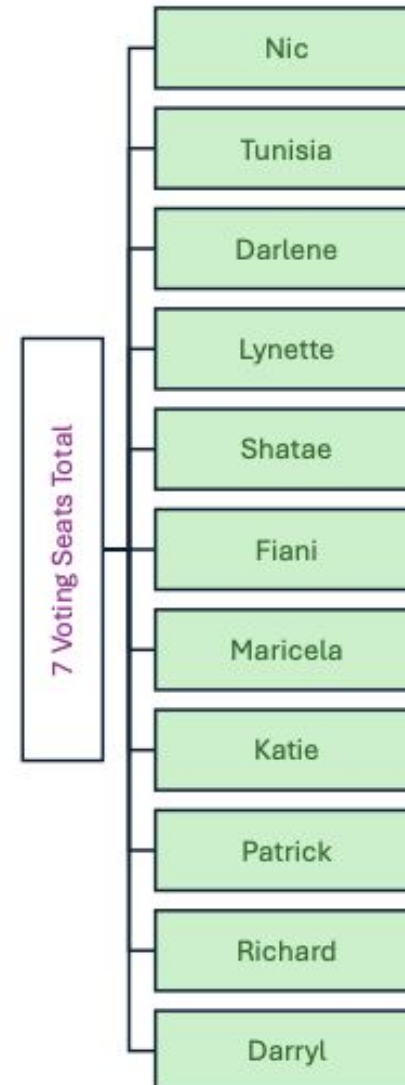
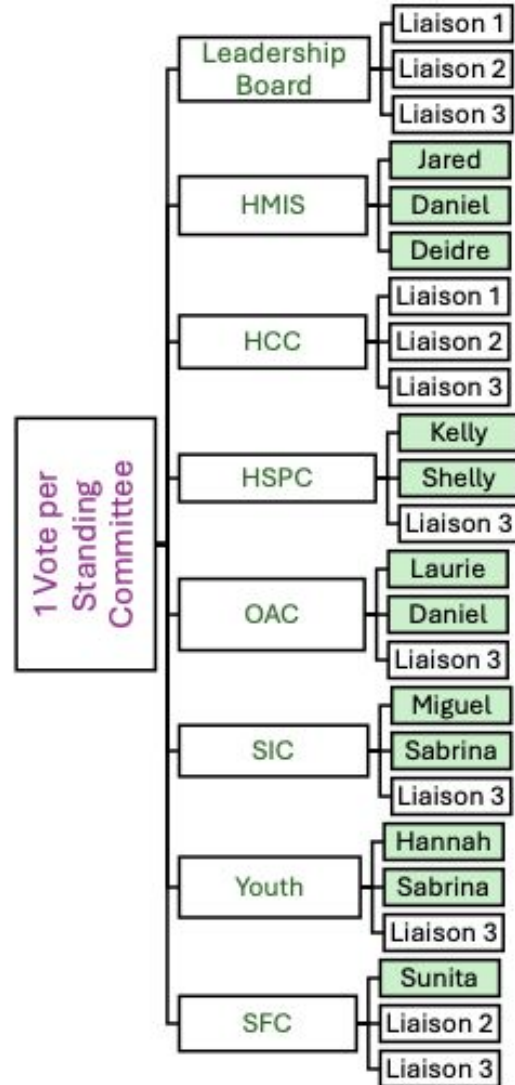

RE Voting Members

Up to three liaisons per standing committee

- Determine 1 regular voting member
- Another liaison(s) will vote if the regular voting member is absent

Up to 7 voting members from Community / At-Large members (at April meeting)

- Determine 7 voting members for 11 members

[Roster of Voting and Non-Voting RE members](#)

Standing Committees & Current Liaisons

HMIS	HSPC	OAC	SIC	Youth	SFC
<ul style="list-style-type: none">• Jared• Daniel• Deidre• Shatae	<ul style="list-style-type: none">• Kelly• Shelley	<ul style="list-style-type: none">• Laurie• Daniel• Maricela	<ul style="list-style-type: none">• Miguel• Sabrina• Jared	<ul style="list-style-type: none">• Hannah• Sabrina	<ul style="list-style-type: none">• Sunita• Tunisia

Note: Leadership Board and HCC have not identified REC liaisons. This may happen in April.

Activity: Voting RE Liaisons

Zoom Break-out based on standing committee

- Determine 1 regular voting member
- Another liaison(s) will vote if the regular voting member is absent. Committees may update name of voting liaisons at any time.
- Return to main group and confirm Voting RE Liaison

[Roster of Voting and Non-Voting RE members](#)

15 REC Voting Members

Seats - RE Liaisons	Member Name	Seats - At Large	Member Name
Leadership Board		AL/Community Member	
CoC Standards, Compliance and Funding		AL/Community Member	
HMIS		AL/Community Member	
Housing Capacity		AL/Community Member	
Housing Stability and Homelessness Prevention		AL/Community Member	
Outreach Access & Coordination		AL/Community Member	
Youth		AL/Community Member	
		AL/Community Member	

April - Voting Community Members

Confirm community seats, HCC and LB Liaisons

- Build committee RE expertise and lived experience
- Meet composition benchmarks

[Roster of Voting and Non-Voting RE members](#)

Liaison Development

Chloé Greene and Nic Ming

30 minutes



Role of Liaisons

REC liaisons serve as an equity touchpoint in committee conversations and work

- Liaisons will communicate key information between committees and the REC
- Support independent REC initiatives and projects
- REC liaisons **will not** carry the full responsibility of the CoC's racial equity work as that is a CoC wide commitment, but will help committees to embed racial equity in our approach to ending homelessness.
- Liaisons will receive resources and tools from the REC to help facilitate equity work and be effective in this role.



Racial Equity Framework:

Liaison Supports and Impact on Racial Equity Workplan

Link to framework [here](#).

Office Hour deck [here](#).



RE Liaison Skill Building - Focus Areas

COMMUNICATION

ADVOCACY

COLLABORATION

SYNERGY



Role of Liaisons: What's Going on in Your Committee?

REC liaisons serve as an equity touchpoint in committee conversations and work. Liaisons will communicate key information between committees and the REC.

- To support liaisons in communicating key information and to share as an equity touchpoint, it is important that REC meetings and workgroups serve as sharing spaces.
 - Will help the REC to work together to support a CoC wide commitment to embed racial equity in our approach to ending homelessness.
 - Want to start committee report outs as a consistent practice so that we can workshop issues together and discuss emerging topics that need more attention.



Communication

Areas to Grow:

- Listening
 - [Background conversations](#) and [Deep Listening](#)
 - RE Liaison Reporting out to Standing Committees and Reporting from Standing Committees to REC - See [template](#)



System Updates & Announcements

Homebase
30 minutes



Updates/Announcements

- CoC Updates in General
- NOFO Committee – (ACTION) REC Member to Serve
- HUD TA Training Session on Coordinated Entry – Chloe
- HHAP 5 Application Workgroup – Nic
- Use of AI Tools Meeting Policy - Nic



CoC General Updates

Racial Equity Framework Office Hours

Thurs 3/21 at 11:00 am- 12:30 noon

Save the Date - April 25th

The Spring General Community Meeting at the Cal Endowment

Jonathan Russell, formerly of BACS

New Director of OHCC as March 2024

NOFO Workgroup REC Rep(s)

Monthly ongoing meetings to support updates to CoC's annual HUD NOFO application process

'Temporary Policy on the Use of AI in Meetings'

Committees are asked to pilot the changes and provide their feedback to the Leadership Board for consideration toward a final policy. The next anticipated opportunity to reconsider the policy is August 2024.



HHAP-5 Application

Joint Alameda County and Oakland application

- **Timeline: by March 22, 2024**
- RE Components must include already happening
- **REC + Workgroup on March 21 to work on RE areas**
- Follow up - Lessons Learned to Implement
 - Process and RE Tools for CoC committees and members

HHAP-5 RE Application Areas

Application (draft) Areas of focus

- System Performance Measures with Racial Equity Components
- **Equity Improvement Plan**

HHAP-5 RE Application Areas

[HHAP-5 Application](#) (draft) Areas for + RE details:

- 2.3 Equity Improvement Plan

- Service Delivery
- Housing Placements
- Housing Retention
- Procurement

[RE Areas](#) 2.3 Equity Improvement Plan pgs 24 - 28

HHAP-5 RE Activities

REC to work on application

- **Timeline: by March 22, 2024**
- **REC + Workgroup on March 21 to work on RE areas of the application**
- RE Components must incl already happening
- Follow-up: RE Liaisons activities and HHAP-5/Other Funding

CE Evaluation

Coordinated Entry System to manage and prioritize resources

- HUD Requirement, State and Local Funding requirement
- OHCC is Designated CE Management Entity in CoC org chart
- OAC committee manages evaluation process
- Last CE Evaluation - completed early 2023

CE Evaluation RE Areas and Activities

REC Action and RE Liaisons to OAC support

- Communication and sharing between OAC and REC about RE areas of CE evaluation process
- Coordinating RE spaces for learning - RE Coordinated Entry Learning Session in April
-

RE Committee Agenda April 11, 2024

Homebase
10 minutes



RE Committee April Agenda draft:

- Seat REC Voting Members Round 2
 - Meet New OHCC Director
 - Equity Framework
 - CoC Community Meeting April
-

ADJOURN MEETING

April RE Workgroups/Workshops:

- Thursday, April 4: REC Leadership and Skills Development - Communication
 - Thursday, April 18: RE and System Measures for Committees
-

CoC Community Meeting April- RE Opportunity

ADJOURN MEETING



Racial Equity Framework

Brief Community Presentation

Discussion

Implementation Strategy

Etc.



Reference Slides

Acronym	Definition
BIPOC	Black, Indigenous, Person of Color
CES	Coordinated Entry System
CoC	Continuum of Care: A geographic region awarded funding by HUD each year in a collaborative application process
ERF	Encampment Resolution Fund
HCC	Housing Capacity Committee
HHAP	Homeless Housing Assistance and Prevention Grant
HHIP	Housing and Homelessness Incentive Program
HRC	Housing Resource Center
HSHP	Housing Stabilization and Homelessness Prevention Committee
HUD	US Department of Housing and Urban Development
LB	Leadership Board

Acronym	Definition
NOFO/NOFA	Notice of Funding Opportunity: The annual (summer) competition for CoC funding
OAC	Outreach Access Coordination Committee: That's us!
PIT	Point in Time Count: The count held every January of currently homeless households in the CoC
PSH	Permanent Supportive Housing: A type of CoC funded project that pays long-term, permanent housing subsidy for clients
PWLE	Person with Lived Expertise/Experience: Someone who has been homeless or is currently homeless
REC	Racial Equity Committee
RRH	Rapid Rehousing: A type of CoC funded project that pays short to medium term housing subsidy for clients
SCC	System Coordination Committee: The former name of the OAC
SFC	Standards, Funding, and Compliance Committee
SI	System Impact Committee
SSO	Supportive Services Only: A type of CoC funded project which includes staffing but not housing